

Model 920

Digital Transducer Instrument

Instruction Manual



***Instrument Part No. 080920-01000
Software Version 0.2n***

TABLE OF CONTENTS

I.0 PRELIMINARIES.....	3	3.0 INSTRUMENT SETUP & CALIBRATION.....	7
I.1 PRECAUTIONS.....	3	3.1 STARTING UP THE 920.....	7
I.1.1 Site Considerations.....	3	3.2 NON-SMART TRANSDUCER SETUP.....	7
I.1.2 Handling.....	3	3.3 TEST SETUP.....	8
I.1.3 Cleaning.....	3	3.4 CHANGING FREQUENCY RESPONSE.....	9
I.1.4 On Re-packing.....	3	3.5 DISABLING ID CHIP SEARCH.....	9
I.1.5 Before You Begin.....	3	3.6 END-OF-RUN PACKET.....	9
I.2 INTRODUCTION.....	4	3.7 TORQUE WRENCHES W/LED LIGHTS	10
I.2.1 How to Use This Manual.....	4	3.8 SPINDLE MODE.....	10
I.2.2 Model 920 Operation Overview..	4	4.0 OPERATION.....	11
I.2.3 Transducer Selection.....	4	4.1 TAKING DATA.....	11
I.2.4 Test Setup.....	4	4.2 REVIEWING DATA & STATISTICS	11
I.2.5 Data Recording.....	5	4.3 PRINTING DATA AND STATISTICS	11
I.2.6 Viewing Data.....	5	4.4 SENDING DATA TO A COMPUTER.....	11
I.2.7 Data Storage & Upload.....	5	4.5 ERASING DATA.....	12
I.3 CONNECTIONS.....	5	4.6 SETTING DATA & TIME.....	12
I.3.1 Pinouts.....	5	4.7 SETTING BAUD RATE.....	12
I.3.2 Printer/Computer Upload.....	5	4.8 PROCEDURE FOR COUNTING ANGLE IN DIAGNOSTIC MODE.....	12
2.0 INSTRUMENT OVERVIEW	6	4.9 CHARGING THE BATTERY	13
2.1 THE MAIN SCREEN.....	6	5.0 SPECIAL APPLICATIONS	14
2.2 CAL SCREEN OVERVIEW	6	5.1 TESTING HAND TORQUE WRENCHES.14	
2.3 SETUP SCREEN OVERVIEW	6	5.1.1 Equipment Required.....	14
2.4 STORE SCREEN OVERVIEW	6	5.1.2 Setting Up The Model 920	14
2.5 UTILITIES SCREEN OVERVIEW	6	5.1.3 Testing Hand Wrenches.....	15
		6.0 SPECIFICATIONS.....	16
		6.1 SPECIFICATIONS.....	16

I.O PRELIMINARIES

I.I PRECAUTIONS

Please observe the following precautions.

I.1.1 Site Considerations

The Model 920 is a portable instrument. It can operate for up to 8 hours on the fully charged internal battery.

Since the Model 920 is computer equipment, take the same precautions with it as you would a portable or laptop personal computer.

Do not set up or operate in close proximity to heat sources such as radiators or air ducts.

I.1.2 Handling

The Model 920 is a durable design, but avoid situations that will induce vibration and avoid dropping the instrument.

I.1.3 Cleaning

Since The Model 920 instrument is computer equipment, use the same cleaning routine as you would for a laptop computer. The Model 920 is not watertight so do **NOT** let the unit get wet. Keep solvent type cleaners away from the front panel display. Care for the keypad as you would for a personal computer.

I.1.4 On Re-packing

Do not throw away the shipping carton and packing materials if possible. They make an ideal container in which to transport the unit should it need to be shipped to another site. A carrying case (PN 38180-000960) is available from RS Technologies.

I.1.5 Before You Begin

NOTE

Notes in this manual are enclosed in shaded boxes such as this one.

Check the packing list to be sure that all equipment, transducers, cables, and other accessories were shipped with your meter.

If you have any questions about this unit, its setup and operation do not hesitate to contact your RS Technologies distributor, representative, or the factory for technical support.



Figure I. Model 920 Front Panel, showing keypad and main screen

1.2 INTRODUCTION

This introduction provides an overview of the manual and the Model 920 instrument.

1.2.1 How to Use This Manual

This manual is arranged to help you quickly find the information you need for the operation of the Model 920. The manual consists of the following sections.

- ▲ Preliminaries, Section 1.0, provides an introduction to the instrument and the manual
- ▲ Preparation, Section 2.0, provides an overview of the instrument
- ▲ Instrument Setup, Section 3.0, describes transducer and test setup
- ▲ Operation, Section 4.0, covers taking data with the Model 920
- ▲ Special Applications, Section 5.0, provides information about special applications for which the Model 920 can be used
- ▲ Specifications, Section 6.0, provides specifications

To locate a topic of interest, first look through the Table of Contents. If you are already familiar with digital instrument operation, read starting from Section 3.0, Instrument Setup. If you are new to this kind of instrument, please read through the entire manual to completely familiarize yourself with this equipment.

1.2.2 Model 920 Operation Overview

The Model 920 recorder is fully configurable for production applications. Setting it up for use is a simple, menu-driven process. The actual steps depend upon whether or not the instrument and transducers have already been set up. Normal operation is made up of the following steps:

1. Connect the transducer that will be used, whether or not it has already been set up and defined.
2. Turn on the power at the power switch. The 920 briefly displays an introduction screen

that includes the software version number. This number should be obtained before making a technical support call.

3. The 920 looks to see if the connected transducer contains an identification microchip and displays a screen that tells you so.
4. If the 920 finds a smart transducer, it retrieves the stored information; if the 920 does not find a smart transducer, you may select to use the current transducer or select a different transducer. Refer to paragraph 3.2. At this point the 920 starts a calibration.
5. When the calibration is complete, the 920 displays the results and then displays the main screen.
6. Set up a new test or modify existing test setup. Refer to paragraph 3.3.
7. Run the test. Refer to paragraph 4.1.
8. View or print data or send it to a remote device. Refer to paragraphs 4.2 or 4.3.

1.2.3 Transducer Selection

There is a library of standard RS Technologies transducer models that can be selected for use. This library includes 5 custom user-defined transducers you may set up for use. The transducer library is displayed by pressing the CAL key. After a transducer is selected, you are prompted to verify the calibration value. After doing so, or entering a new calibration value, the 920 prompts you through a calibration.

1.2.4 Test Setup

You set up the test parameters by pressing the SETUP key. The 920 displays the setup screen from which you make the entries or selections that tailor the instrument to suit your testing requirements. Refer to paragraph 3.2.

1.2.5 Data Recording

The Model 920 recorder features one channel for obtaining torque-only, torque and angle, or force measurements. The tracking value for torque, angle, or force data is displayed in real-time during the test. The 920 also displays the peak value. The 920 is equipped with AutoSave and AutoReset features that allow you to save the data and reset the instrument for the next test automatically, without any manual button pushing.

1.2.6 Viewing Data

The Model 920 lets you view the recorded data or statistics. Press the STORE key to display the store screen. You then make selections to view or print either the numerical data in memory or the current statistics report.

1.2.7 Data Storage & Upload

The Model 920 stores up to 300 readings. The data can be uploaded to a laptop or personal computer via the serial port using the HyperTerminal application provided with Microsoft Windows, or some other similar serial port communication programs. Test data can then be archived or opened by a spreadsheet or word-processing application for further review, analysis, or report generation.

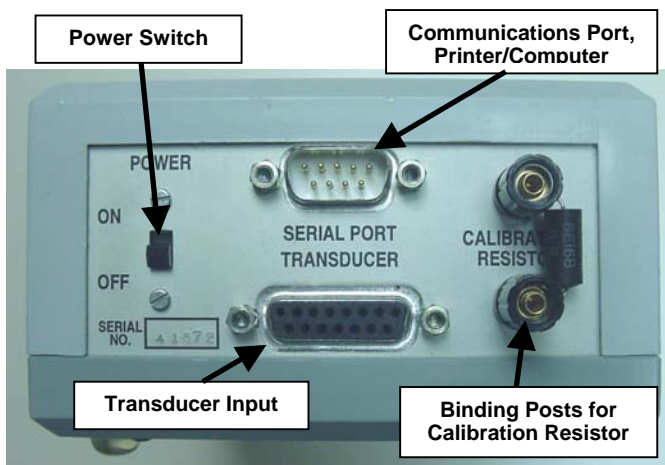

Figure 2. Model 920 End Panel

generation.

1.3 CONNECTIONS

In order to record data with this instrument, the transducer must be properly connected to the Model 920. If recording from a single torque-only, torque-angle, or force sensor, simply connect the sensor to the DB-15 receptacle labeled TRANSDUCER. See Figure 2.

1.3.1 Pinouts

The Model 920 uses the following pinouts for connecting transducers to the DB-15 TRANSDUCER input receptacle.

Pin	Function	Pin	Function
1	-Signal	9	+ Excitation
2	+Signal	10	- Excitation
3	GS1	11	GS3
4	GS2	12	GS4
5	Analog Ground	13	Shunt
6	ID Data	14	Lead CW
7	Encoder 5V	15	Trail CCW
8	Digital Ground		

A jumper must be added when wiring a connector for the Model 920 in order to scale the output of the transducer or input device properly.

Jumper Position	Signal Level
3 & 12	Up to 2.5 mV/V
4 & 12	Up to 4.5 mV/V
None	Up to ± 5 vdc

1.3.2 Printer/Computer Upload

Connect the local printer to the Printer DB-9 serial receptacle labeled SERIAL PORT. If connecting a computer to receive an upload of data, connect the computer to the Printer DB-9 serial receptacle. **NOTE:** Use a Null Modem or Data Link serial cable for transfer to a computer.

2.0 INSTRUMENT OVERVIEW

2.1 THE MAIN SCREEN

All operations start from the main screen whether you are ready to run the test or are setting up a new test or transducer. Refer to Figure 1. The main screen displays the following:

- ▲ TRACK mode input that shows the current transducer input value
- ▲ PEAK value that was captured on the last cycle
- ▲ The angle of rotation in degrees (if used)
- ▲ Cycle status displayed as “READY” to indicate that the 920 is ready to record data, “IN CYC” to indicate that the 920 is in the middle of a test cycle
- ▲ The number of cycles recorded (lower right hand corner)

While the Main Screen is displayed, pressing one of the following keys initiates a special function.

CAL displays the calibration screen where you select, define, check, and calibrate transducers.

SETUP displays the setup screen where you define test limits or parameters, set the direction of test rotation (CW or CCW), set engineering units, and set the sample size for statistical calculations.

STORE displays the store screen where you can view all readings in memory, the current statistics report, and perform printing functions.

UTILS displays the utility screen where you can delete the last cycle or clear all of the results, set the date and time, set the frequency response, or reset the factory default values.

When displaying one of these screens described above, the following keys are used.

ARROWS are used to move between selections.

ESC is used to return to the previous screen.

ENTER is used to make selection or save any changes.

2.2 CAL SCREEN OVERVIEW

The calibration screen lets you select, define, and calibrate the transducers used with the 920. There is a library of standard RS Technologies torque transducers and room for five (5) custom transducers accessible from this screen. This screen also lets you enable/disable the automatic detection of the smart-transducer ID chip. In addition, you can view the raw signal data from the transducer via this screen.

2.3 SETUP SCREEN OVERVIEW

The setup screen lets you set up the test by setting limits, engineering units, test direction, and sample size for statistics.

2.4 STORE SCREEN OVERVIEW

The store screen lets you view all readings in history, view the current statistics report, or print the readings or statistics report.

2.5 UTILITIES SCREEN OVERVIEW

The utilities screen lets you clear the last reading or all readings, set the date and time, change the frequency response, reinstall the factory default values, or change the printer baud rate. You can also select the filter setting, enable/disable Spindle Test Mode, enable the Send End of Rundown data packet (EOR), or enable/disable the hand torque wrench LEDs.

3.0 INSTRUMENT SETUP & CALIBRATION

3.1 STARTING UP THE 920

Use the following procedure to power up the Model 920.

1. Connect the transducer that will be used to the TRANSDUCER connector on the Model 920. Make sure that the correct cal resistor is installed on the external binding posts (see Figure 2). If using a non-standard or custom transducer refer to paragraph 3.2.
2. Turn on the power at the power switch. The 920 briefly displays an introduction screen that contains the software version number. It's helpful to make a note of the version number before making a tech support call.
3. The 920 checks to see if the connected transducer contains a smart transducer ID microchip and displays a screen that tells you so.
4. If the 920 finds a smart transducer, it retrieves the stored information and begins transducer calibration as described in Step 6.

NOTE

The transducer information is displayed in the current engineering units.

5. If the 920 does not find a smart transducer, it displays information about the transducer that was last used with the instrument. You can select to use the currently displayed transducer by pressing the ENTER key, or you can choose to select a new transducer by pressing the 1 key.
 - A. Pressing 1 lets you access the Model 920 transducer library. Use the arrow keys to scroll through the library and locate the desired transducer by model number and capacity. When the correct transducer is highlighted, press the ENTER key. You can then enter or update the transducer's calibration value, press the down arrow key to select the number of decimal

places, and then press ENTER to save your changes and ESC to the calibration screen. Proceed to Step 6.

- B. If the transducer you want to use is not listed in the library, it needs to be set up in the Model 920 as described in paragraph 3.2.
6. The CALIBRATION screen identifies the currently selected transducer and calibration value. The 920 prompts you to remove any load from the transducer and press ENTER. When the calibration is complete, the 920 briefly displays the results and then re-displays the main screen.
 7. You're now ready to check the test setup. See Paragraph 3.3.

3.2 NON-SMART TRANSDUCER SETUP

The three basic steps for setting up the Model 920 with a transducer that doesn't contain a smart ID chip is to define the transducer, select it for use, and then calibrate it. Use the following procedure to select and calibrate a transducer that does not have an RS Tech ID chip.

Note

You may find it helpful to change the engineering units to those used by the transducer that you wish to set up. This can be done by accessing the setup screen. Refer to paragraph 3.3, Step 13.

1. From the main screen, press the CAL key.
2. Press 2 and the 920 displays the define customer transducer screen.
3. Press the arrow keys to select the user-definable transducer you want to set up. Up to five custom transducers can be set up and stored in the 920. When the desired transducer number is displayed, press the ENTER key.

4. In the FS (*units*) field enter the full scale capacity of the transducer and press the ENTER key.
5. Press the down arrow key and enter the calibration value in the CAL (*units*) field.
NOTE: *The calibration value can be located on the calibration certificate provided with the transducer. As with the full scale capacity, be sure to enter the desired number of decimal places. Press the ENTER key.*
6. Press the down arrow key and enter the correct number of angle encoder pulses in the PPR field. Enter 0 for transducers without angle encoders. Press the down arrow key.
7. Press the ENTER key to save your changes and then press the ESC key to move back to the calibration screen.
8. Press 1 to select an automatic calibration of the transducer.
9. When the Model 920 displays the transducer ID information, make sure the correct calibration resistor is mounted in the external binding posts on the connector panel of the 920.
10. Remove any load from the transducer and press the ENTER key. The 920 first adjusts the zero balance, then spans the 920 to match the shunt calibration value for the transducer. After a successful calibration, the 920 re-displays the calibration screen.
11. Press the ESC key to return to the main screen.

3.3 TEST SETUP

After the transducer is selected and calibrated, the next step to setting up the Model 920 for use is to review and set the testing parameters. Use the following procedure to set the torque limits on the Model 920.

1. From the main screen, press the SETUP key to display the setup screen.
2. Press 1 to display the define limits screen.
3. In the Start (*units*) field enter the transducer input level that will start the test. This value is where the cycle recording begins and is usually set at around 10-20% of the target value. When the transducer input rises about this value, the Model 920 will start looking for the peak value. If checking “click-type” torque wrenches, set this value higher to about 60% of the target. For example, if checking a wrench set at 100 in-lbs, set the START value to around 60 in-lbs. After making the entry, press the down arrow key.

Note

For more on torque wrench testing see Section 5.1.

4. In the End Time (*sec*) field, enter the amount of time that should expire before data recording is stopped.

NOTE

The Start and End Time values work together to end the recording cycle. When the transducer input drops below the value set in the Start field for the length of time set in End Time field, the recording is completed.

5. In the Measure field, press the ENTER key to toggle the display between PEAK TQ and CLICK TQ. To record just the peak or maximum data point produced by the transducer, select PEAK TQ; to record the “click” point of a hand torque wrench, select CLICK TQ. Most testing with the Model 920 will use PEAK TQ mode. Press the down arrow key to advance to the next setup field.
6. In the Low (*units*) field enter the low limit of acceptable torque or force and press the down arrow key. This value is used for calculating statistics.

7. In the High (*units*) field enter the high limit of acceptable torque or force and press the down arrow key. This value is also used for calculating statistics.
8. If your transducer has an angle encoder (the transducer PPR is set to something other than 0), you can set limits for angle measurement. If your transducer does not have an angle encoder, skip to Step 11. In the Low (*deg*) field enter the low limit of angle measurement and press the down arrow key.
9. In the High (*deg*) field enter the high limit of angle measurement and press the down arrow key.
10. With the View field displayed, pressing the ENTER key will toggle between FINAL ANG and ANG @ PK. This lets you select between displaying the angle recorded between Start and the peak torque value (ANG @ PK), or the angle between Start and when data recording was stopped. After making your selection, press the down arrow key.
11. Press the ENTER key to save your changes and then press the ESC key to return to the setup screen.
12. Press the 2 key to toggle between CW (clockwise) and CCW (counterclockwise). This indicates the direction of the test. Typical tightening curves are recorded in clockwise direction. Release angle studies are typically done in counterclockwise.
13. Press 3 repeatedly to cycle through the available engineering units until the desired units are displayed. Those currently available are Lbft, Lbin, Nm, Kgcm, Kgm, ozin, Lb, N, and kN. The conversion of all torque or force values is done automatically.
14. Press the 4 key to select the sample size for statistical calculations.

15. In the SAMPLE SIZE field enter the desired number for the sample size. This can be any number from 3 to 25 depending upon the statistical requirements of the test or process. To use all readings in the population as the sample size enter 0.
16. Press ENTER to return to the Setup screen.
17. Press ESC to return to the main screen.

3.4 CHANGING FREQUENCY RESPONSE

If it is desirable to change the frequency response of the instrument to suit the test requirements, press the UTILS key to display the utilities screen. Press 3 to toggle through the available frequencies (500 and 1000 Hz and OFF). When the desired frequency is displayed, press the ESC key to return to the main screen.

3.5 DISABLING ID CHIP SEARCH

The Model 920 software is set up to automatically search the transducer for an ID chip when the instrument is powered up and when a calibration sequence is started. If the transducers you are using do not have ID chips, disabling this feature will speed up set up time. To keep the Model 920 from searching for an ID chipset when turning on the meter and when starting a calibration sequence, press the CAL key from the main screen and note the setting for Item 4. Smartducer-ON indicates that the ID chip search is turned on; Smartducer-OFF indicates that the ID chip search is turned off. Press the 4 key to change the setting. Enabling/disabling the ID chip search is password protected. After making this selection you will be prompted to enter the password (default=268) and then the 920 will toggle this feature to the opposite state.

3.6 END-OF-RUN PACKET

If you want to have the Model 920 send a packet of data at the end of each test or run, this feature can be enabled from the Utilities menu. From the main screen press the UTILS key. Then press the 4 key

twice. The screen should show either 1)EOR Pkt: MANUAL or 1)EOR Pkt: SEND. This toggles the 920 between sending the run data automatically after each cycle (SEND) or only after sending the data by hand (MANUAL).

3.7 TORQUE WRENCHES W/LED LIGHTS

Some RS Technologies electronic hand torque wrenches come with an integral tri-color LED. This can be used to alert the operator if the recorded data is in- or out-of-specification. The low and high torque limits set in the Model 920 (Paragraph 3.3, Steps 6-7) are used to trigger a below limit status (yellow light), above limit status (red light), or within limit status (green light) following the test cycle. To enable this feature, start at the main screen and press the UTILS key. Then press the 4 key twice to reach the third page of the Utilities menu. Pressing the

2 key will toggle the Model 920 between enabling or disabling this feature. 2)Sensor LED:ON = enabled; 2)Sensor LED:OFF = disabled.

3.8 SPINDLE MODE

Spindle Mode is used to measure the angle only while the torque input is above the setting for cycle Start (see paragraph 3.3, Step 3). To enable this mode, start from the main screen and press the UTILS key. Then press the 4 key once to reach the second page of the Utilities menu. Enabling or disabling the Spindle Mode is password protected. To change the setting, press the 3 key, enter the password (default = 268), and the setting will be toggled to the other setting. 3)Spindle Mode: ON = enabled; 3)Spindel Mode: OFF = disabled. After setting this feature, press ESC twice to return to the main screen.

4.0 OPERATION

4.1 TAKING DATA

Use the following procedure to record data with the Model 920. This procedure assumes that the transducer has been selected and calibrated per paragraph 3.1, and that the test has been set up per paragraph 3.2.

1. With the main screen displayed, make sure the READY indication is displayed in the lower left corner of the screen.
2. Run down the fastener, or apply the load as required by the test.
3. The track and peak values will increment as the load increases and the "READY" indication in the lower left corner is replaced with "IN CYC" once the transducer input rises about the setting for Start.
4. When the test is complete, the 920 stores the data, resets for the next test, and displays "Ready" in the lower left corner of the display. The previous peak value is displayed and the number of cycles in the lower right-hand corner is updated to indicate how many data points are stored in memory.

4.2 REVIEWING DATA & STATISTICS

After data has been recorded and stored in the Model 920, you can view it by pressing the STORE key. Make your selections as detailed below.

1. Press 1 to view all of the data in memory in the order that they were recorded starting with the most recent. This is called the View All History report. The number of each reading is indicated along with an indicator of whether the data was within or outside the limits, the date and time of the reading, and of course, the data itself. Press the arrow keys to scroll through the readings. Hold down one of the arrow keys to scroll quickly through the readings. Press the ESC key to return to the Store screen. Press ESC again to return to the main screen.

2. Press 2 to view the statistics. This is called the View Statistics report. Press the down or up arrow key to scroll through the statistics. Displayed are the number of readings, the low reading, mean reading, high reading, the range of readings, the standard deviation, +3 sigma, -3 sigma, Cpk, and Cp. When finished reviewing the statistics, press ESC to return to the Store screen. Press ESC again to return to the main screen.

4.3 PRINTING DATA AND STATISTICS

After data has been recorded, you can print it out using the following procedure.

1. Connect a serial printer to the serial port (portable battery-powered printer is available from RS Technologies, PN 089504-DP414)).
2. To print the stored data or statistics report, press the STORE key to display the store screen.
3. To send all of the numeric data to the printer, press the 3 key.
4. To send the statistics report to the printer, press the 4 key.
5. After making your selection and completing the print job, press ESC to return to the main screen.

4.4 SENDING DATA TO A COMPUTER

Use the following procedure to upload the recorded data and statistics to a laptop or desktop computer.

NOTE

The computer will receive data via the HyperTerminal application that is provided with Windows operating systems.

1. Connect the Model 920 to a serial port of the computing device using a 9-pin Null Modem

or Data Link serial cable (available from RS Technologies, PN 38190-3000010).

2. Start the HyperTerminal application on the computer. The executable file is *hypertrm.exe*.
3. The first time you use HyperTerminal with the 920, you will need to set up the connection. If you have already done so, simply click on the connection icon and go to Step 7. If you haven't yet setup a connection follow Steps 4-6.
4. HyperTerminal displays the *Connection Description* dialog box into which you enter a name for the connection and choose the icon that will be associated with the connection and placed in the HyperTerminal program group. Enter an appropriate name into the field, such as "Direct to Model 920", choose an icon, and then click on OK.
5. In the *Connect To* dialog box, select the communications port that you will be using in the *Connect Using* field. Make sure the port you choose is functional on your computer. Then click on OK.
6. In the *Com x Properties* dialog box that is displayed confirm the communications protocol (x = com port number). Make sure the baud rate of the com port matches that of the Model 920 (9600 is recommended). Refer to paragraph 4.7. Click on OK.
7. In the *Transfer* menu of HyperTerminal, select the option you prefer from the following: 1) *Capture Text* will show the information on the screen and place it in a file that you designate; 2) *Capture to Printer* will transfer the data to the local printer attached to the computer.
8. Once you have made your selection in Step 7 above, go to the 920 and select the report you want to upload, as described in paragraph 4.3. Prn History: All is a list of all readings in the order that they were taken; Prn History: SS contains the data and statistics.

9. The data is transferred to the computer in ASCII text format and can be manipulated using most common word processing, spreadsheet, or similar applications that can import ASCII files.
10. Press the ESC key on the 920 when ready to return to the main screen.

4.5 ERASING DATA

Two options are provided with the Model 920 to erase data: one lets you erase all data in memory; the second lets you erase the last recorded cycle in memory. To do so, press UTILS from the main screen and the 920 displays the utilities screen. Press 1 to display the memory screen. Then press 1 to delete the last reading or press 2 to clear all results from memory.

4.6 SETTING DATA & TIME

To update the date and time, press the UTILS key to display the utilities screen. Then press 2 to display the set date and time screen. With this screen you can enter the correct month, day, year, hour (using 24-hour time base), and minutes. Enter the correct values using the numeric keys. Press the down arrow key to move to the next setting. Press the ENTER key to save your changes and then press ESC to return to the utilities screen. Press ESC to return to the main screen.

4.7 SETTING BAUD RATE

Pressing the UTILS key followed by the 4 key can set the baud rate for the printer. Press the 2 key to toggle through the available selections. When finished, press the ESC key to return to the main screen.

4.8 PROCEDURE FOR COUNTING ANGLE IN DIAGNOSTIC MODE

In cases where it is desired to measure a certain angle of rotation without

1. From the Main Screen, press the CAL button.

2. When the Calibration Menu is displayed, press the 3 button to display the Check Transducer screen.
3. In the upper line you will see the raw Analog-Digital counts of the torque input.
4. In the second line you will see the raw angle counts displayed. As the transducer is rotated, this number increases or decreases according to the number of counts per revolution of the transducer. For RS Tech transducers $\frac{1}{4}$, $\frac{3}{8}$, and $\frac{1}{2}$ -inch drives one revolution will produce 1440; for $\frac{3}{4}$ -inch drives one revolution will produce 2160 counts; for 1-inch drives and larger one revolution will produce 2880. Other manufacturers may produce different results.
 - For $\frac{1}{4}$ -inch, $\frac{3}{8}$ -inch, and $\frac{1}{2}$ -inch drives divide the number of counts by 4 to determine the actual number of degrees.
 - For $\frac{3}{4}$ -inch drives, divide the number of counts by 6 to determine the actual number of degrees.
 - For 1-inch and larger drives, divide the number of counts by 8 to determine the actual number of degrees.
5. To reset the angle counter, press the ESC button to display the Calibrate screen. Then press the 3 button to re-display the Check Transducer screen.

NOTE

The Check Transducer screen is used primarily as a diagnostic feature to determine that the Model 920 is receiving torque and angle signals from the transducer. This can be particularly useful if there is a question regarding the continuity of the transducer cable or a problem with the transducer.

4.9 CHARGING THE BATTERY

The Model 920 is provided with a battery charger (PN 9412R-002100) that can be used with either 120 VAC or 220 VAC. When the Model 920 displays the Lo Bat indication, plug the charger into a suitable power supply source and plug the other smaller connector into the 920 instrument on the side. The red LED indicator on the 920 will remain lit while the battery is being charged. The battery charging circuitry protects the battery from damage while the charger is plugged in.

NOTE

Operating the Model 920 with the battery charger plugged in *may* cause electrical noise in the measuring circuitry.

5.0 SPECIAL APPLICATIONS

5.1 TESTING HAND TORQUE WRENCHES

Refer to the following procedures when verifying or calibrating hand torque wrenches.

5.1.1 Equipment Required

To verify the performance of hand torque wrenches you will need the following equipment.

1. Model 920 Digital Instrument, PN 080920-01000
2. Torque transducer, preferably a 7000 Series Stationary Torque Sensor mounted to a table or suitable base. A rotary square drive torque sensor can be substituted if mounted in a suitable fixture where one end is held stationary and the load is applied to the other end.
3. Transducer cable.
4. Printer (optional).

5.1.2 Setting Up The Model 920

After setting up and calibrating the torque transducer that you will use to test the hand torque wrench as described in either Section 3.2.1 or Section 3.2.2 of the Model 920 Manual, the next step to setting up the Model 920 for use is to set the testing parameters. Use the following procedure to set the torque limits on the Model 920.

1. From the main screen, press the SETUP key to display the setup screen.
2. Press 1 to display the define limits screen.
3. In the Start (*units*) field enter the transducer input level that will start the test. This value is where the cycle recording begins. For testing hand torque wrenches and “Click-type” hand wrenches, this should be set to about 60% of the setting of the wrench. For example, if the wrench is set to release or “click” at 100 in-lbs, the Start torque value should be set to 60

in-lbs. After you have entered the desired value, press the down arrow key.

4. In the End Time (*sec*) field, enter the amount of time that data is recorded following the Cycle End and press the down arrow key. This value can be left at the default value of 1.0 sec or less.

NOTE

The Start and End Time values work together to end the recording cycle. When the transducer input drops below the value set in the Start field for the length of time set in End Time field, the recording is completed.

5. In the Measure field, press the ENTER key to toggle the display between PEAK TQ and CLICK TQ. To record the “click” point of the hand wrench, select CLICK TQ; to record just the peak or maximum applied torque, select PEAK TQ. Press the down arrow key to advance to the next setup field.
6. In the Low (*units*) field enter the low control limit of acceptable torque and press the down arrow key. This value is used for calculating statistics.
7. In the High (*units*) field enter the high control limit of acceptable torque and press the down arrow key. This value is also used for calculating statistics.
8. Press ENTER to save all changes.
9. Press ESC to return to the setup screen.
10. If needed, press 2 to toggle the direction of the test between CW and CCW.
11. If needed, press 3 repeatedly to cycle through the available engineering units until the de-

sired units are displayed. Those currently available are Lbft, Lbin, Nm, Kgcm, Kgm, ozin, Lb, N, and kN. The conversion of all torque or force values is done automatically.

12. If necessary, press the 4 key to select the sample size for statistical calculations.
13. In the SAMPLE SIZE field enter the desired number for the sample size. This can be any number from 3 to 25 depending upon the statistical requirements of the test or process. To use all readings in the population as the sample size enter 0.
14. Press ENTER to return to the setup screen.
15. Press ESC to return to the main screen.

5.1.3 Testing Hand Wrenches

Refer to the following guidelines when attempting to test hand torque wrenches.

1. Clear any unneeded readings from the memory of the Model 920. Refer to Section 4.5 if necessary.
2. Position the drive of the wrench in correct fitting on the torque transducer. Allow enough

room for the operator to pull the wrench to reach the desired torque.

3. If checking the reading of a “dial-type” wrench, simply pull the wrench to the desired reading and release the wrench. Compare that value to the displayed Peak Torque value on the Model 920. Typically 5-10 tests are required to satisfy the necessary sample size requirement for most tool testing standards. Consult the manufacturer’s specifications and technical information to determine if adjustments to the wrench are necessary to ensure accurate operation and use.
4. If checking a “click-type” wrench, apply torque to the wrench by pulling in a slow, steady manner through the “click” point, then release the handle. The Model 920 will search through the recorded torque to find the point at which the wrench “clicked” and released. Typically 5-10 tests are required to satisfy the necessary sample size requirement for most tool testing standards. Consult the manufacturer’s specifications and technical information to determine if adjustments to the wrench are necessary to ensure accurate operation and use.

6.0 SPECIFICATIONS

This section provides a listing of the instrument specifications.

6.1 SPECIFICATIONS

The following specifications apply to the Model 920. Some special system program configurations may include or delete identified features.

A/D Resolution	16 bit
Accuracy	±0.5% FS Peak Mode ±0.25% FS Track Mode
Angle Input	Quadrature, dc-14 mHz
Angle Resolution	Depends upon counts/rev of transducer
Bridge Excitation	5 vdc
Calibration	Shunt cal via external binding posts
Communications Port	RS 232 serial for printout or upload to computer via HyperTerminal or similar serial port utility
CW/CCW Operation	Software selectable
Data Memory	Automatic storage of 300 peak torque-angle or force readings, scrolling feature for viewing readings, last reading deletable
Dimensions	2.750 inches depth x 4.375 inches wide x 8.500 inches high
Display	LCD, 20 alphanumeric characters by 4 lines with 5-digit data readout plus 6 digits for angle
Enclosure	High impact plastic with shoulder strap

Engineering Units.....	Software selectable (lbf, lbin, ozin, Nm, kg-cm, kgm, lb. and N)
Frequency Response	10 kHz standard, software programmable filter equiv. to 500 and 1000 Hz
Humidity	5 to 95% N.C.
Input Power	Metal Hydride (NimH) battery, AC adapter 115 vac, low battery charge warning
Input Signal	Compatible with conventional strain gage transducers with outputs ranging from 0.8 to 5.0 mV/V and with high level devices up to ±5 vdc
Keypad	16-key numeric and special function
Maximum Angle Count	10,000 degrees
Operating Temperature	0-55 °C
Options	Multiple limit sets
Printout	Transducer and limits data, time and date stamped peak data, angle at peak (if used), and statistics
Recommended Recalibration	Yearly
Statistics	High, low, mean, standard deviation, ±3 sigma, Cpk, and Cp; calculations based on programmed sample size or entire population
Supplied with	Battery charger, instruction manual, shoulder strap
Warranty	One year from date of receipt
Weight	1.5 lbs.

RS Technologies, Ltd.
24350 Indoplex Circle
Farmington Hills, Michigan 48335
Telephone: (248) 888-8260
FAX: (248) 888-8266
email: info@rstechltd.com
www.rstechltd.com

